

# AVK COMBINATION AIR RELIEF VALVE, PN16

701/70

The Series 701/70 is a double orifice air relief valve, suitable for use with sewage, raw water, brine and sludge, to a maximum temperature of 70°C.

## Features:

- Only 17kg in weight.
- Rilsan® coated aluminium body.
- Drainage and flushing bosses.
- Large orifice will discharge air from pipelines to over 1 bar.
- Small orifice discharge 10 times greater than from conventional units.
- Reduction in hammer and surge in systems.
- Highly corrosion resistant.

## Options:

- Isolating gate valve.
- Bevel gearbox.
- DZR brass ball drain valve.
- Vented non-return valve.
- Small single orifice version (701/73).
- Reduced height version (701/74)



The designs, materials and specifications shown are subject to change without notice due to our continuing programme of product development.

# AVK COMBINATION AIR RELIEF VALVE, PN16

701/70

## TESTS

Hydraulic test .  
Seat: 16 bar high. 0.2 bar low Body: 24 bar.

## APPLICABLE STANDARDS

Inlet flange to BS EN 1092-2: 1997

## SERVICE CONDITIONS

Maximum Working Pressure: 16 bar.  
Temperature Range: -10°C to+70°C. Insulation essential for temperatures of 0°C and below.

## MATERIALS OF CONSTRUCTION

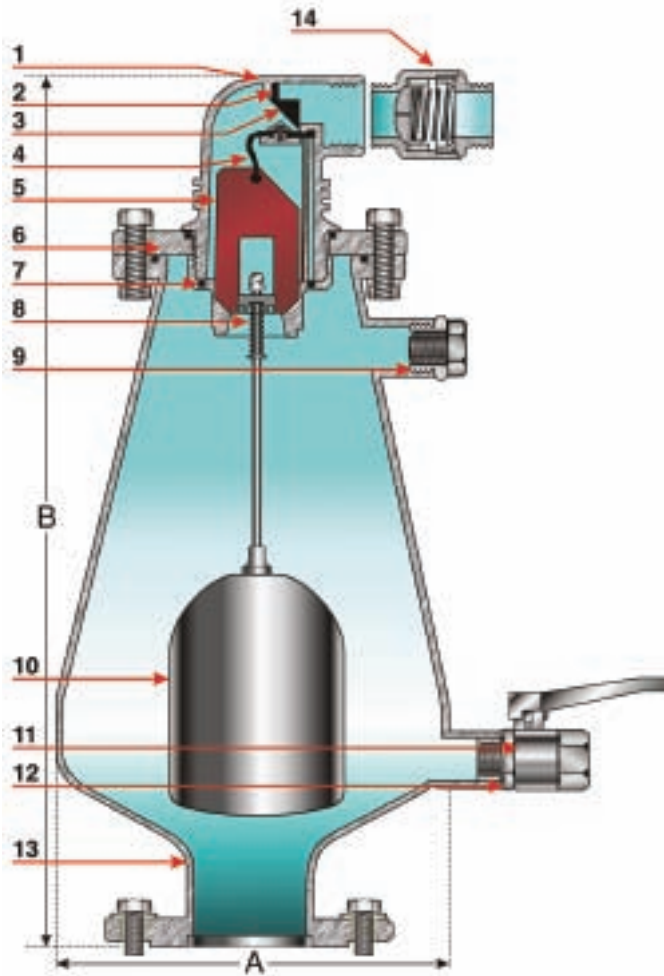

No.	DESCRIPTION	MATERIAL
1	Cover	Glass filled nylon.
2	Small Orifice	Automatic – 14mm <sup>2</sup> .
3	Large Orifice	Kinetic – 804mm <sup>2</sup> .
4	Rolling Seal Assembly	Seal: EPDM. Support: polypropylene. Screw: stainless steel.
5	Secondary Float	Foamed polypropylene.
6	Top Flange Assembly	Flange: aluminium LM6. Bolts / Nuts: stainless steel. O ring x 2: EPDM. Bolt hole bushings: glass filled nylon with stainless steel cap.
7	O Ring	EPDM.
8	Push-Rod Assembly	Rod: stainless steel Gr 316. Nut and spring: stainless steel.
9	Flushing Boss	Threaded bush: uPVC. Assembly Threaded plug: uPVC 1" BSP.
10	Primary Float	Stainless steel AISI 316.
11	Ball Valve (optional)	DZR brass BS 2874 CZ 132.
12	Drainage Boss Assembly	Threaded bush: uPVC. Threaded plug: uPVC.
13	Body Assembly	Cast aluminium LM6. Bolt hole bushing: Glass filled nylon with stainless steel cap.
14	Vented Non-Return Valve Unit	Body: Glass filled nylon. Disc: Glass filled nylon. Seal: EPDM. Spring: Stainless steel.
	Coating	Black Rilsan® Nylon 11.

## DIMENSIONS & WEIGHTS

Ref No	DN	A mm	B mm	Weight kilos
701-080-70043003	80	270	605	17
Air valve with gate valve:	DN	Overall width	Overall height	Weight kilos
701-080-70043053	80	429	811	35



AVK UK Limited

**Northampton Office**  
8 Rushmills, Northampton,  
NN4 7YB England, UK.  
Tel.: +44 (0) 1604 601188  
Fax.: +44 (0) 1604 604818

**Chesterfield Office**  
Colliery Close, Ireland Ind. Est., Staveley,  
Chesterfield, S43 3FH, England, UK.  
Tel.: +44 (0) 1246 479100  
Fax.: +44 (0) 1246 479200

www.avkuk.co.uk